

MINI-STRIKER®

SERIES



MINI-STRIKER®

LIGHTWEIGHT PRESSURE FIRE PUMP

The **WATERAX MINI-STRIKER®** pump pairs a reliable single stage pump end with the Honda 4-stroke 2.5 HP engine to achieve pressures of up to 85 PSI (5.9 BAR) and offer volume supply of up to 80 GPM (303 L/Min). Extremely portable and lightweight, this mini powerhouse performs well when used by itself or in tandem with other pumps, and is a very popular choice for entry level slip-on applications. It is also particularly suited to some of the latest fire control techniques where small, lightweight equipment is a requirement. The widely-available Honda 4-stroke 2.5 HP engine makes for ease of operation and engine parts sourcing.

Emissions compliant; engine is CARB and EPA certified

Applications

- Attack line firefighting
- Sprinkler operations
- Tandem pumping over long distances
- Entry level slip-on units

Features and Benefits

- Lightweight aluminium alloy pump components
- Portable and compact
- Comprehensive user and service manuals

SPECIFICATIONS

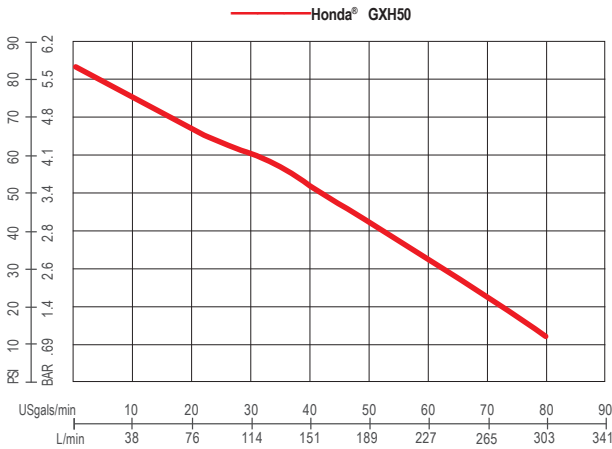

Flow rate at specified pressure

Maximum Pressure: 85 PSI (5.9 bar)
 Freeflow: 80 USgals/min (303 L/min)
 Maximum Head: 196' (60 m)

Flow Rate		Pressure		
US GPM	(LPM)	@	PSI	(BAR)
68	(257)	@	25	(1.7)
42	(159)	@	50	(3.4)
12	(45)	@	75	(5.2)

Engine: Honda® GXH50

Engine Specifications

- Model & Type** Honda, GXH50 Series 4-stroke, horizontal shaft, single cylinder, OHV
- Net Power Output** 2.1 HP (1.6 kW) @7000 RPM
- Net Torque** 2.0 lb-ft (2.7 Nm) @4500 RPM
- Bore & Stroke** 1.65 x 1.42 inches (41.8 x 36 mm)
- Displacement** 3.01 cubic inches (49.4 cc)
- Starting System** Recoil
- Ignition** Transistorized Magneto
- Governor** Centrifugal Mechanical
- Air Cleaner** Semi-dry
- Cooling** Air Cooled
- Lubrication** Forced Splash
- Oil Capacity** 0.26 quarts (0.25 liters)
- Carburetor** Float Type
- Emissions** Meets current CARB, EPA, and CE requirements.
- Exhaust** US Forestry Service Approved Spark Arrestor
- Fuel Type** Gasoline [unleaded, 86 minimum octane or higher, 10% maximum ethanol]
- Fuel Tank:** Integral 0.81 quarts (0.77 liters)
- Fuel Consumption** 0.17 USgal/hr (0.65 L/hr)

Unit Base Specifications

MSTR-P:
 Black flat polyethylene base with four rubber pads. Unit also provided with a single black composite carry handle mounted on the top for transporting.

Pump Specifications

- Type** Single Stage Centrifugal; Direct Drive
- Description** Low Pressure, Low Flow, Foam Compatible
- Maximum Allowable Pressure** 200 PSI (13.8 bar)
- Maximum Pressure** 85 PSI (5.9 bar)
- Maximum Flow** 80 GPM (303 lpm)
- Intake** 1-1/2" Male NPSH Thread. Protected by Rubber Cap with Retainer (MSTR-P only)
- Discharge** 1-1/2" Male NPSH Thread. Protected by Rubber Cap with Retainer (MSTR-P only)
- Body & Diffusers** Anodized corrosive resistant aluminum
- Impellers** Anodized corrosive resistant aluminum
- Pump Shaft** Stainless Steel
- Pump Seal** Heat Resistant Rotary Mechanical Seal – Maintenance Free
- Color** Red

Controls

Engine choke, shut-off, throttle, and fuel valve control levers with low oil pressure shutdown.

MSTR-V:

Four industrial isolators mounted directly to the engine base with M6 x 1.0 female thread.

All features are not available on every model. Please refer to the product selection matrix to select the proper model.

MSTR-P Length 12-5/8" (32 cm) Width 10-3/4" (27.3 cm) Height 15-1/2" (39.3 cm) Weight 20 lbs(9 kg)

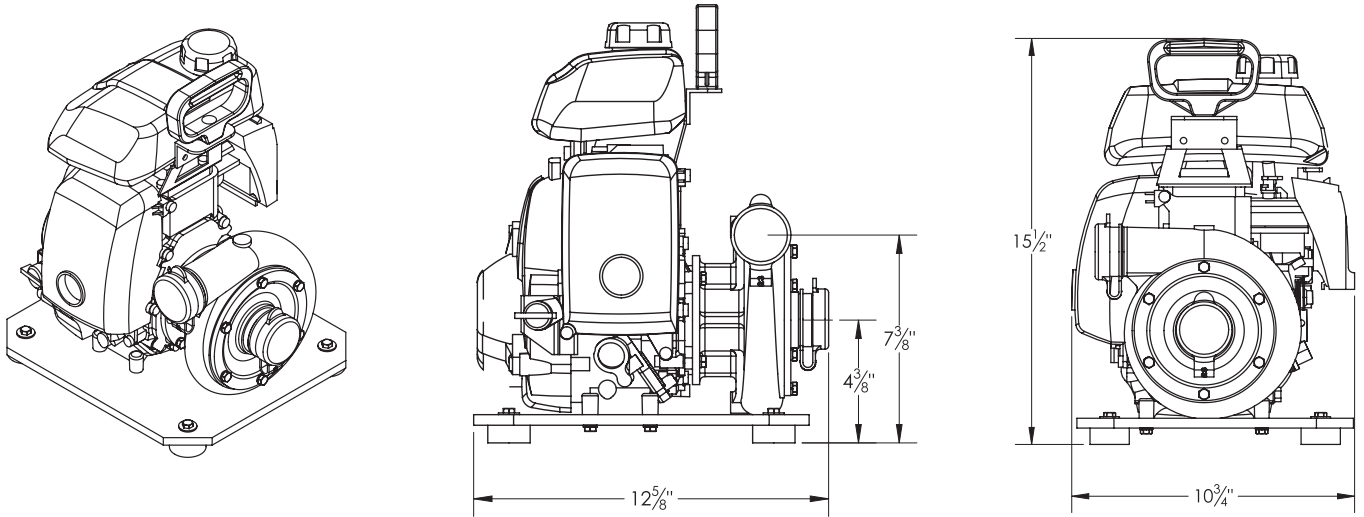

MSTR-V Length 12" (30.4 cm) Width 10-3/4" (27.3 cm) Height 14-7/8" (37.7 cm) Weight 19 lbs(8.6 kg)

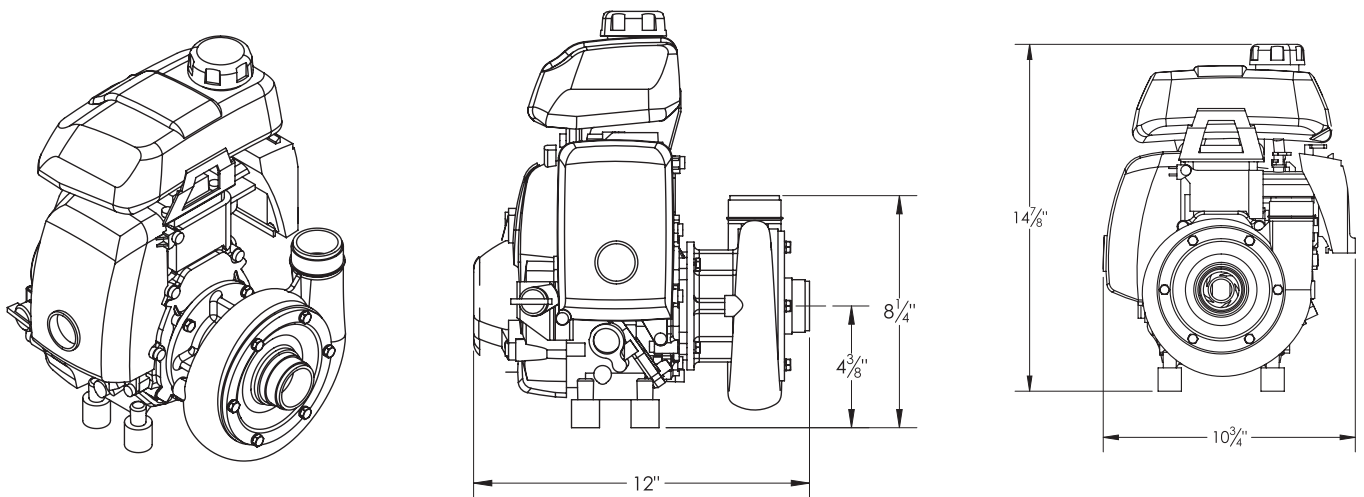

WATERAX

WE MOVE WATER®

WATERAX Inc.
6635 Henri-Bourassa W.
Montreal, QC H4R 1E1

TF855-616-1818

T 514-637-1818

F 514-637-3985

info@waterax.com

www.waterax.com

Distributed by:



Brissmans
BRANDREDSKAP AB

info@brissmans.se
Tel: 035-17 17 90
Skyttevägen 43
302 44 Halmstad
www.brissmans.se

All information contained in this document including drawings is proprietary to WATERAX and may not be copied, reproduced or used in whole or in part without our prior written permission.
The information in this document is subject to change without notice. Model displayed with multiple options. Weight and dimensions are approximated and may vary depending on options.